

## ◆ Product Data ◆

*for supervisory control and Data Acquisition*



# TSRLink® Spread Spectrum Wireless I/O

No Programming- Drop-In wire replacement- Secure Encryption  
Over 10 miles - Unlimited Distance w/ Repeater(s)

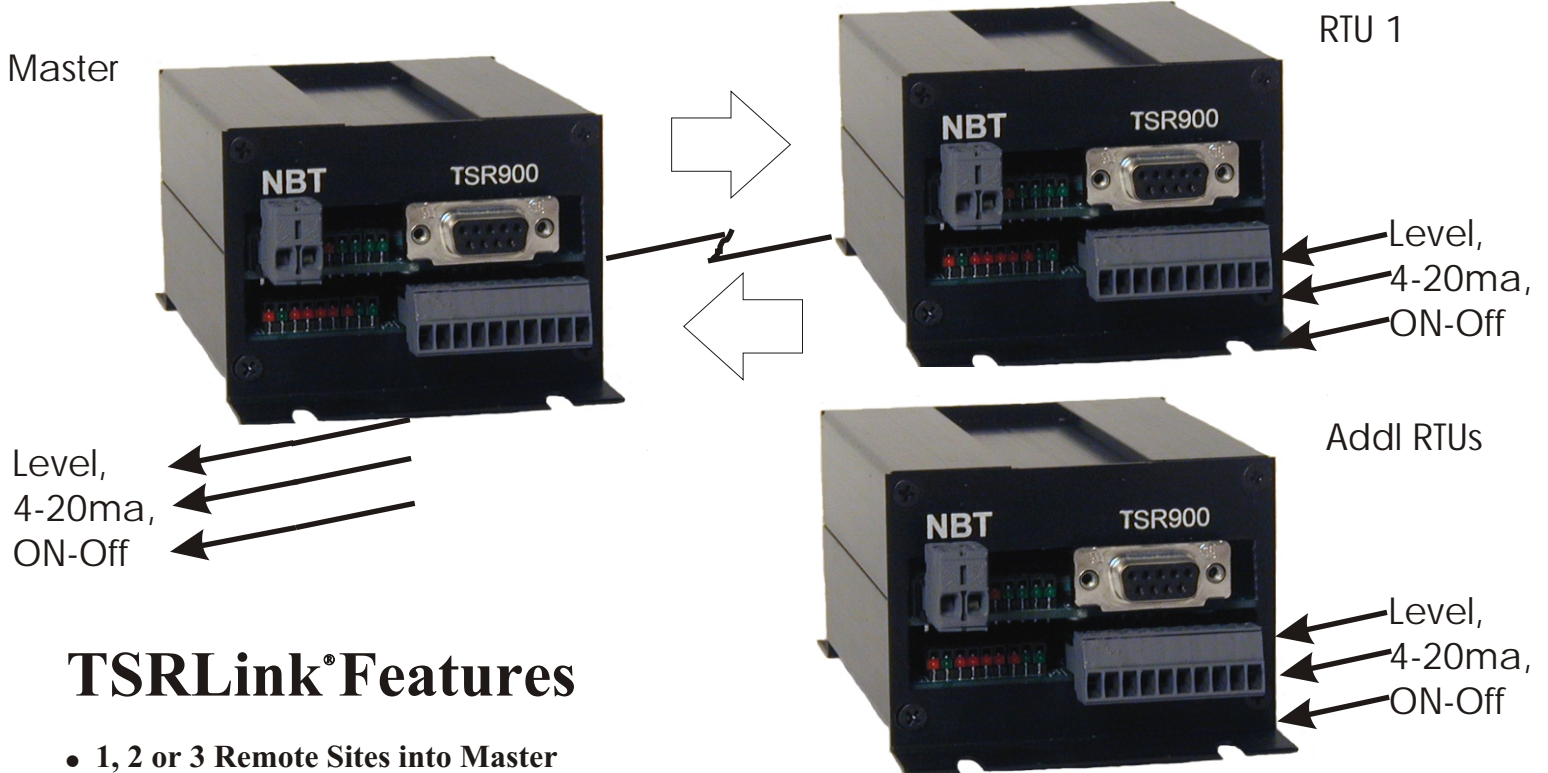

## TSRLink® Features

- 1, 2 or 3 Remote Sites into Master
- 2 Control Outputs sent to any remote
- **Modbus compatible- Easy upgrade to PLC Master**
- Power requirement of 12-24 VDC
- Incredibly small "footprint" ideal for panel mounting
- **Maximum allowable transmit power - 1 Watt**
- Programmable selection of channels
- License free band of the radio spectrum
- Addressing includes station ID, and network address
- Built-in CRC-16 error detection and auto-retransmit to provide accurate and reliable data
- Radio Test Software includes spectrum analysis utility
- Easy to use Windows based radio setup software

- **Avoid Trenching Costs**
- **Eliminate long wire runs**
- **Eliminate phone company problems**
- **Eliminate monthly line costs**
- **The TSRLink is the latest generation of industrialized license-free radio technology.**
- The TSR900 was designed and developed specifically for today's municipal and utility applications.
- Completely upward expandable
- LED indicators -Dig I/O -Comm Status
- **Common alarm/Comm Fail contact output**

**Nota Bene Technology, Inc.**

A Div. of EPG Companies Inc.  
19900 County Rd. 81  
Maple Grove, MN 55311

(952) 928-8872 (800) 892-5303

(952) 928-8874 FAX [www.nbtinc.com](http://www.nbtinc.com)

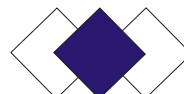

## Nota Bene Technology TSR900 - Technical Specifications

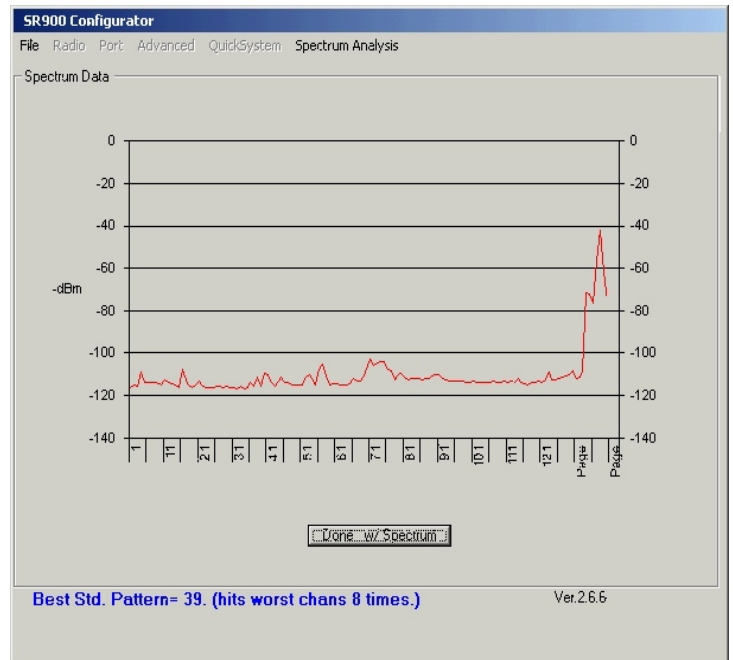
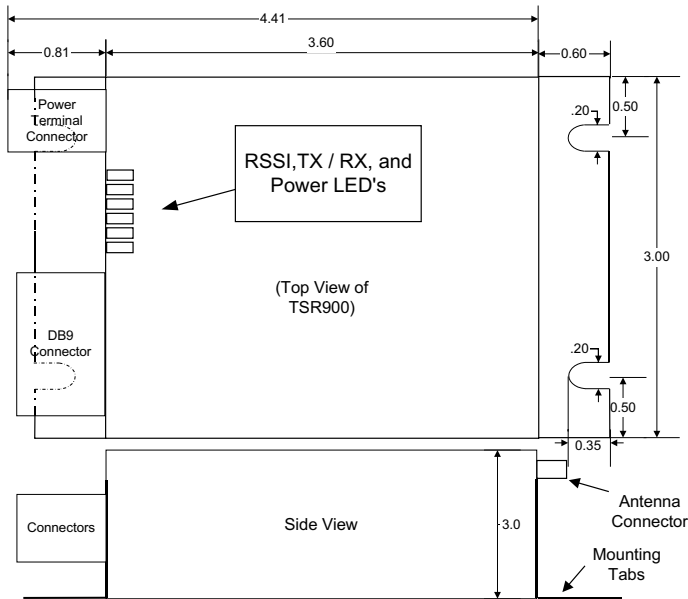

Spectrum analysis utility included with the software

### Transmitter and Receiver Details

Operating Freq.	902-928MHz
System Gain	135 dB
Sensitivity	-105 dBm
Output Power	1mW to 1 W (User-Configurable)
Spread Code	Frequency Hopping
Hopping Pattern	20 pseudo-random, user selectable
Freq. Stability	$\pm 2.5\text{ppm} \pm .00015\%$
TX Keying	Data Activated

#### Transmitter

Output impedance 50 ohms  
 Spurious Emissions , <60 dBa  
 Harmonic Emissions , <60 dBa  
 Power Output .1W to 1 Watt (20 - 30dBm 1dB)

#### Receiver

Double Conversion superheterodyne  
 Intermodulation 75dB minimum  
 Desensitization 60dBc in band, 70dBc out of band  
 Spurious emissions 60dBc In band, 70dBc out of band

#### Primary Power

Transmitter Supply Current	1mW=193mA, 10mW=212mA, 100mW=294mA, 1W=542mA
Receive Supply Current	194mA
Power Requirements	12-24VDC @ maximum of 542mA (see TX & RX specification above)
Reverse Polarity Protection	Diode across primary power input

### General

Approvals	FCC and Industry Canada
Data Interface	Asynchronous Serial - RS232
RS-232 Signals	Sig. Gnd, TX, RX, DSR, DTR, RTS, CTS
Other Signals	CD, RXMode, TXMODE, RSSI1, 2, 3
Communications Range	Up to 19 Miles (30 Kilometers) line-of-sight is optimum
Memory	Nonvolatile configuration memory
Operating Modes	Point-to-point, Point-to-multipoint
Power Requirements	12-24VDC @ maximum of 542mA
Error Detection	CRC-16 with auto-retransmit
Data Latency	25 - 50mS

### Environmental

Dimensions(WxDxH)	3" x 4.8" x 2"
Weight	Approx. 11 ounces
Operating Environment	-40 to +65C; Humidity 5-95% Non-condensing

Visit our web page at  
[www.nbtinc.com](http://www.nbtinc.com)



Nota Bene Technology, Inc.  
 A Div. of EPG Companies Inc.  
 19900 County Rd. 81  
 Maple Grove, MN 55311  
 (952) 928-8872 (800) 892-5303  
 (952) 928-8874 FAX [www.nbtinc.com](http://www.nbtinc.com)